



Installation Instructions

Part Number 33CSUCE-06

PACKAGE CONTENTS

ITEM	QUANTITY
Metal Enclosure Top	1
Metal Enclosure Bottom	1
Mounting Hardware	1
Relay Pack Circuit Board	1

GENERAL

The Carrier Comfort System relay pack serves as an interface between the thermostat, HVAC unit, and any external sensors. The relay pack is used in Monitor-only VVT® (Variable Volume and Temperature) systems and TEMP system applications. The relay pack can be mounted on a wall or inside the HVAC (Heating, Ventilation, and Air Conditioning unit) unit.

INSTALLATION

IMPORTANT: Read these instructions completely before attempting to install the relay pack.

Wiring Requirements — The wiring requirements for the relay pack are:

⚠ CAUTION

Do not ground the shielded wire in more than one location. If the shield is grounded in 2 or more locations, an electrical charge may form around the wire and disrupt thermostat communication.

THERMOSTAT TO RELAY PACK — Wiring must be 18 gage, 5-conductor, shielded, stranded wire, color coded (RED, WHITE, BLUE, YELLOW, and GREEN), plenum rated if required, and long enough to run from thermostat to relay pack.

RELAY PACK TO HVAC UNIT — Wiring must be 6-, 7-, or 8-conductor wire, depending on HVAC unit, and sized to run from relay pack to the wiring terminals of the HVAC unit. A separate transformer should be used. Do not use the unit transformer.

NOTE: Do not run the thermostat network and the control wire in the same conduit for more than 5 ft. Never run wires near any cable carrying AC voltage. For further wiring information, consult the local Carrier distributor.

Power required to each relay pack is 24 vac/10 va. Typical wiring is 18 gage thermostat wire (standard or plenum cable). The maximum load of a relay contact is 24 vac, 1 amp. A short in the field wiring or HVAC unit will cause non-warranty damage to the relay board. Test before attaching to relay pack.

Call the local Carrier representative if more information is needed about wiring the relay pack.

Mount Relay Pack — Perform the following procedure to mount the relay pack:

1. Attach 4 rubber grommets to base. Attach the 4 plastic standoffs to the metal enclosure base with the 4 screws provided. See Fig. 1.
2. Mount the metal enclosure base in a suitable location. See Fig. 2 for enclosure dimensions.

The relay pack should be installed in the HVAC unit control box if climate or space conditions allow. If the temperature range of -30 to 150 F may be exceeded (at a relative non-condensing humidity of less than 95%), then the relay pack should be installed at another location such as a plenum space or utility room.

NOTE: Factory-installed relay packs are available for some Carrier rooftop units. Refer to the Apollo control installation instructions for information on the placement of the factory-installed Apollo control in the rooftop unit.

3. Push the relay pack circuit board down onto the standoffs until it locks into place.

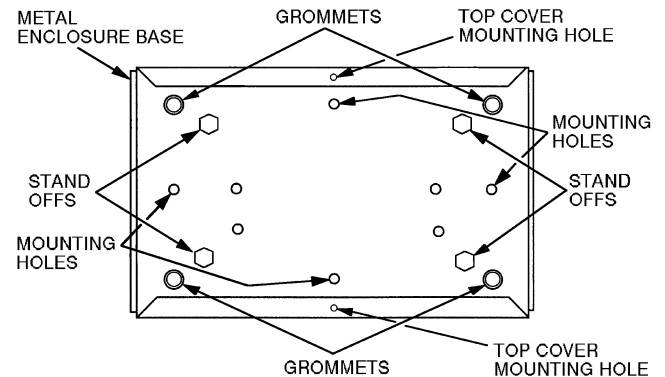
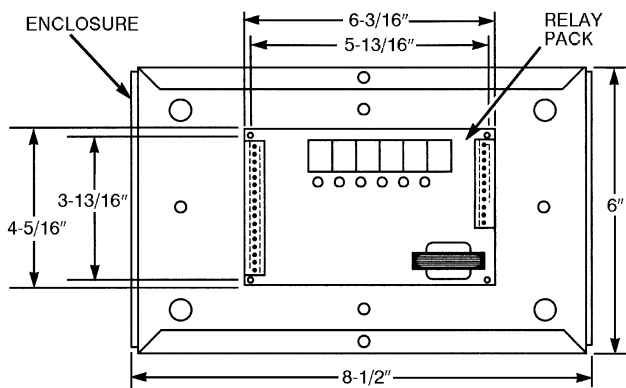

Fig. 1 — Standoff and Grommet Installation



NOTE: Metal enclosure is 2-in. thick with cover on.

Fig. 2 — Metal Enclosure and Relay Pack Dimensions

Wiring Connections

⚠ WARNING

Do not wire relay pack while power is connected. Electrical shock or death could result.

WIRE RELAY PACK TO THERMOSTAT — Wire each thermostat to its respective relay pack as shown in Fig. 3. Wiring connections should be made at the wiring connector board of the thermostat. Route wiring through holes in side of enclosure bottom.

⚠ WARNING

Electric shock can cause injury or death. Ensure power to the transformer has been disconnected before wiring.

WIRE RELAY PACK TO HVAC UNIT — Wire the relay pack to the HVAC unit as shown in Fig. 4-7. All wiring and the relay pack should be kept a minimum of 12 in. away from any cables carrying AC current. Route wiring through holes in side of enclosure bottom. For more information refer to the installation instructions included with each relay pack.

WIRE SENSORS TO RELAY PACK — Wire the sensors to the relay pack. Route wiring through holes in side of enclosure bottom. See Fig. 3.

NOTE: Humidity Sensor and Fan Status Switch cannot be wired to the same relay pack.

Install relay pack enclosure cover with screws provided.

Provide Power to Relay Pack — After the wiring has been completed, provide power to the relay pack. Once power has been provided to the relay pack, the relay pack will provide power to the thermostat. The heating or cooling set points will appear on the thermostat display screen. The thermostat is now ready to be programmed. If the display is blank or blinking, recheck the wiring connections between the thermostat and relay pack. There should be a steady 10 vdc between the red and white connections.

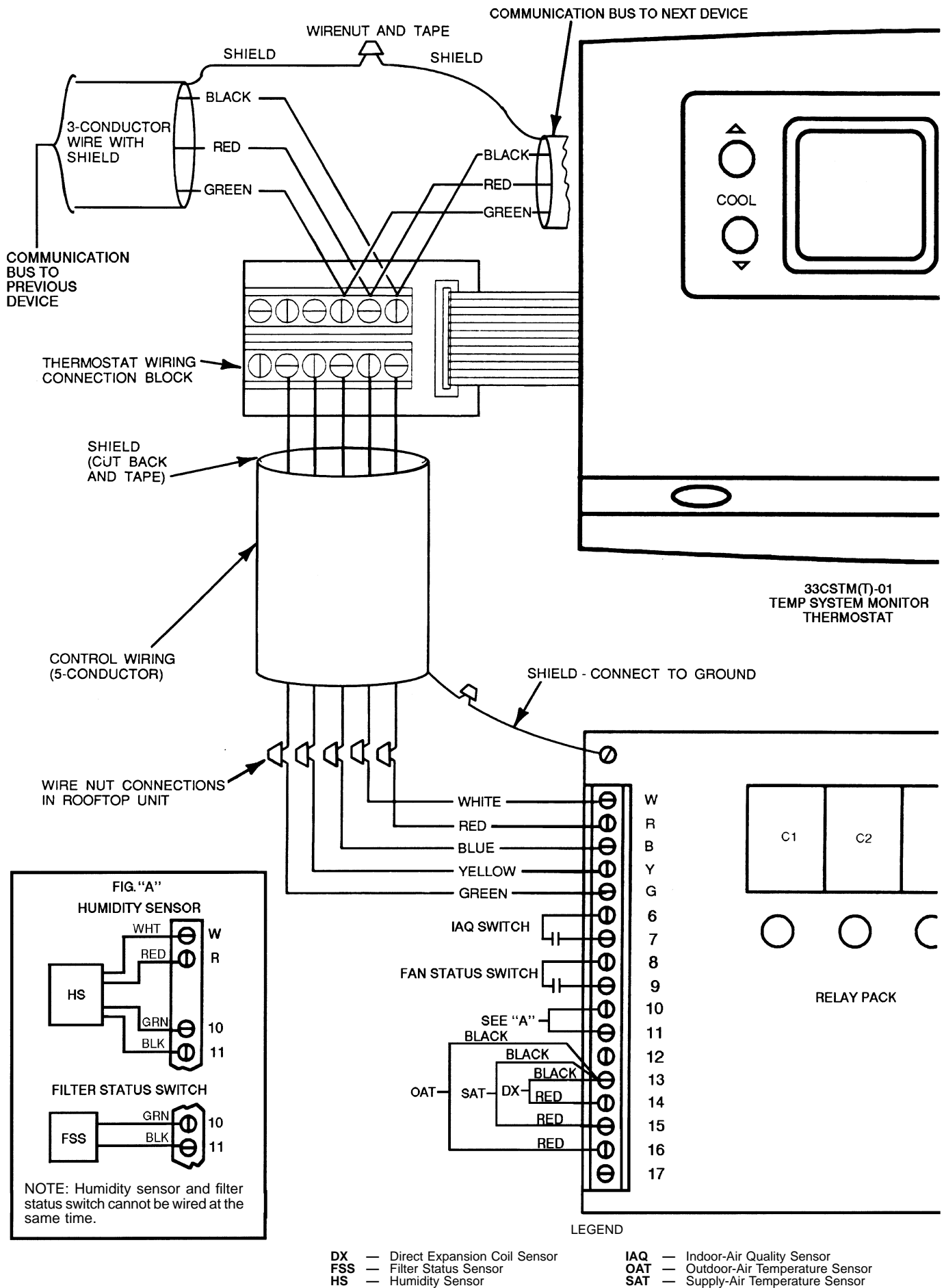
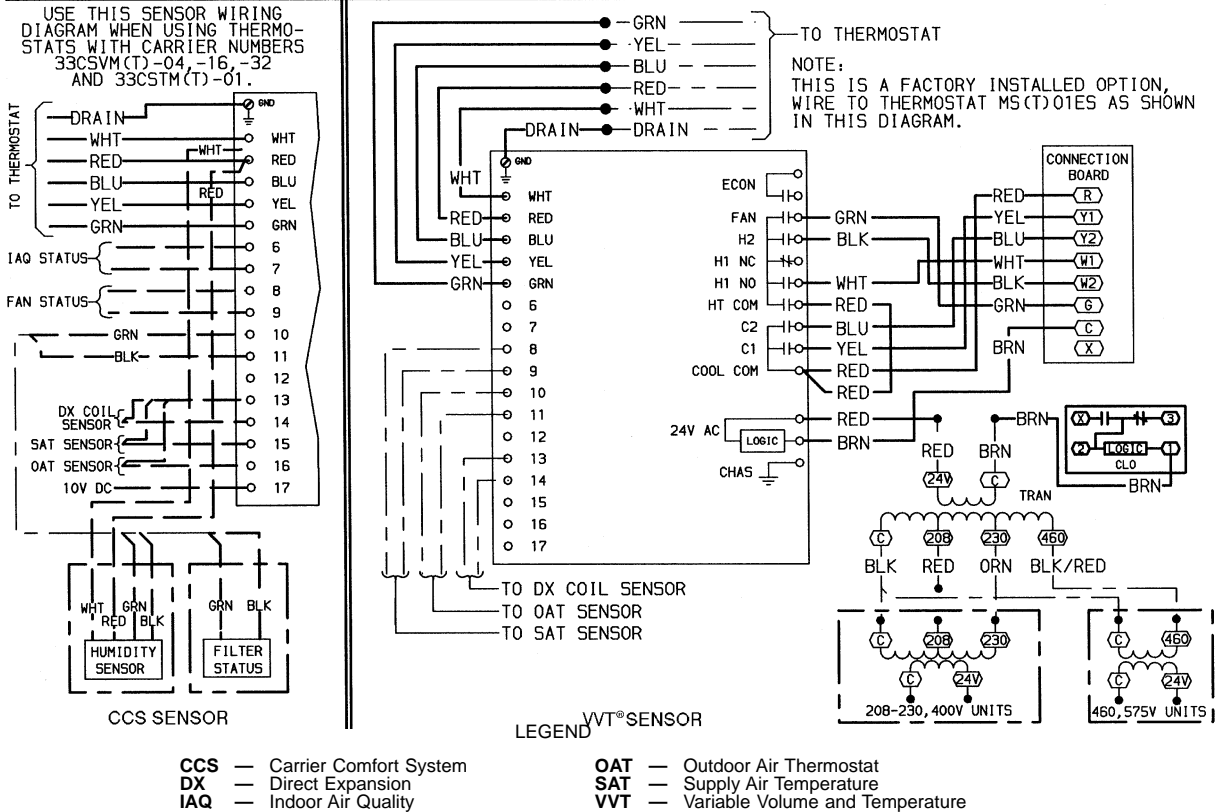

Fig. 3 — Relay Pack to Thermostat and Sensor Wiring

CARRIER COMFORT SYSTEM UNIT CONTROL RELAY PACK - SCHEMATIC



NOTE: The relay pack must be wired to a separate transformer. Do not wire to the unit transformer.

Fig. 4 — Relay Pack to HVAC Unit Wiring, 48/50HJ,TJ004-007 Units

CARRIER COMFORT SYSTEM UNIT CONTROL RELAY PACK - SCHEMATIC

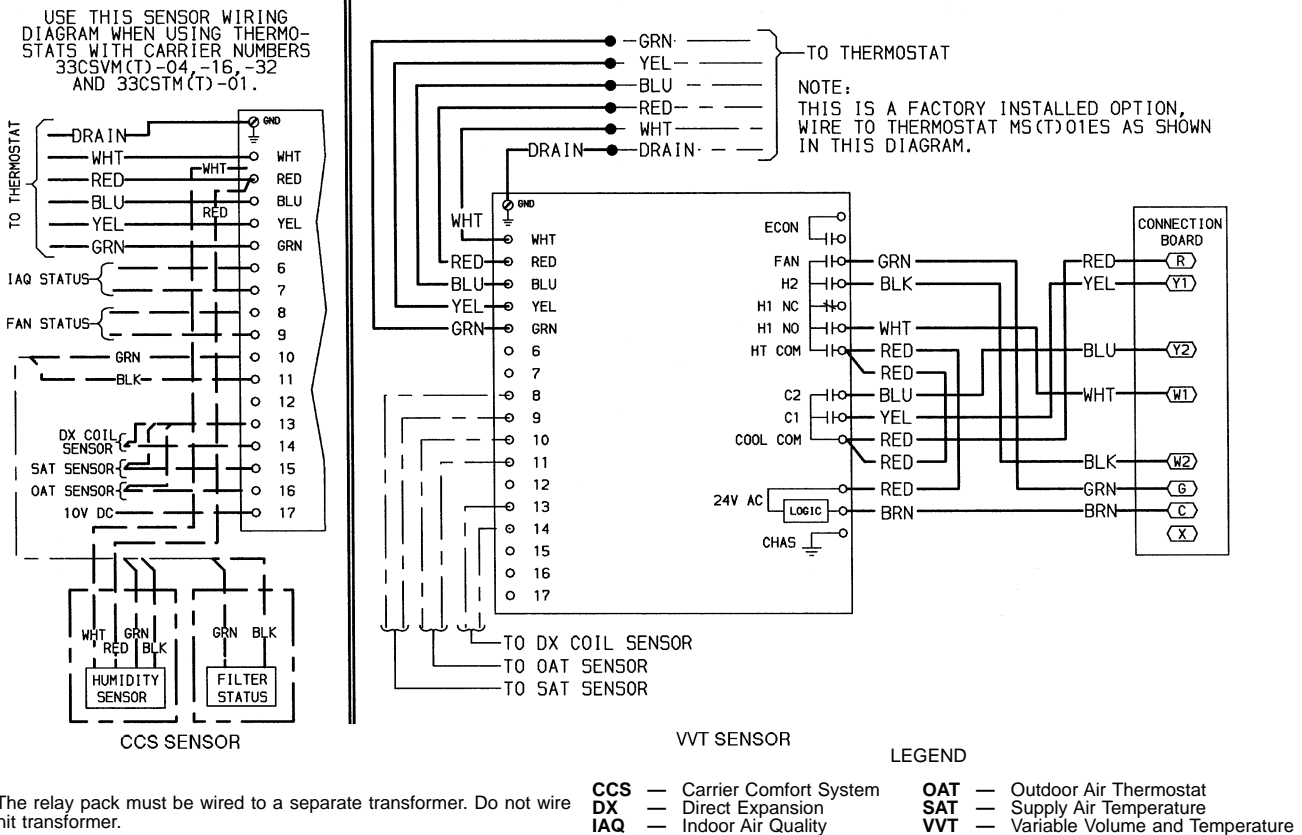

NOTE: The relay pack must be wired to a separate transformer. Do not wire to the unit transformer.

Fig. 5 — Relay Pack to HVAC Unit Wiring, 48/50HJ,TJ008-014 Units

CARRIER COMFORT SYSTEM UNIT CONTROL RELAY PACK - SCHEMATIC

USE THIS SENSOR WIRING DIAGRAM WHEN USING THERMOSTATS WITH CARRIER NUMBERS 33C5VM(T)-04, -16, -32 AND 33C5TM(T)-01.

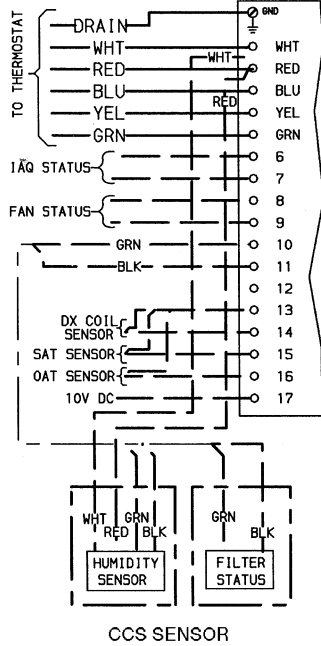

CCS SENSOR

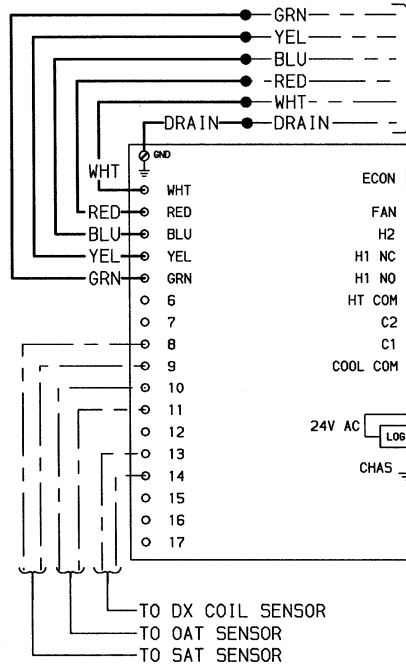

VVT[®] SENSOR

NOTE:
THIS IS A FACTORY INSTALLED OPTION,
WIRE TO THERMOSTAT MS(T)01ES AS SHOWN
IN THIS DIAGRAM.

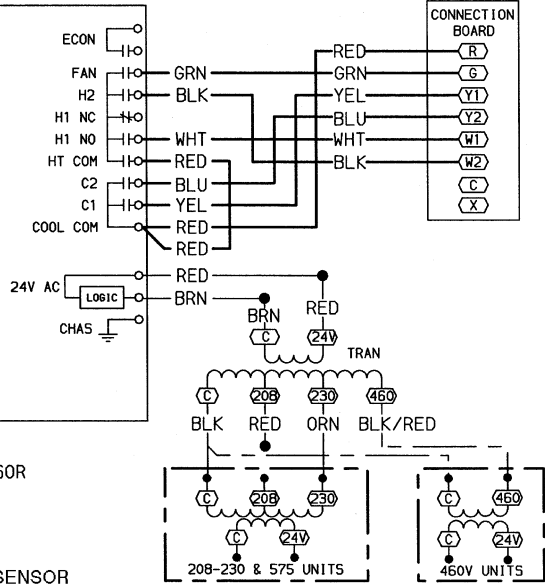

LEGEND

- | | |
|-------------------------------------|--|
| CCS — Carrier Comfort System | OAT — Outdoor Air Thermostat |
| DX — Direct Expansion | SAT — Supply Air Temperature |
| IAQ — Indoor Air Quality | VVT — Variable Volume and Temperature |

NOTE: The relay pack must be wired to a separate transformer. Do not wire to the unit transformer.

Fig. 6 — Relay Pack to HVAC Unit Wiring, 48TJ,HJ016-028 Units

CARRIER COMFORT SYSTEM UNIT CONTROL RELAY PACK - SCHEMATIC

USE THIS SENSOR WIRING DIAGRAM WHEN USING THERMOSTATS WITH CARRIER NUMBERS 33C5VM(T)-04, -16, -32 AND 33C5TM(T)-01.

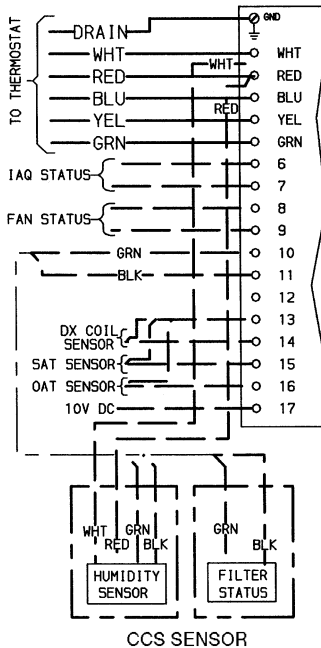

CCS SENSOR

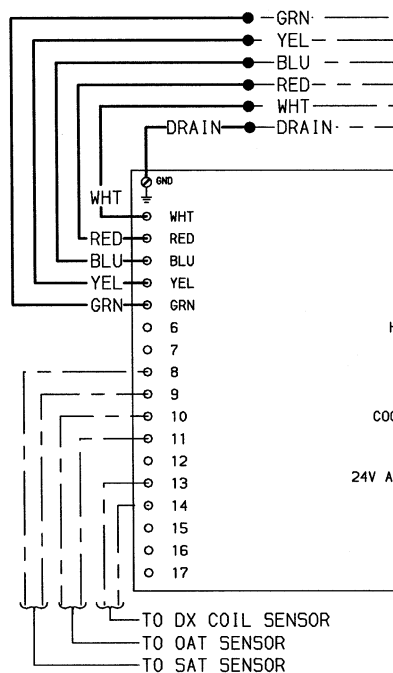

VVT SENSOR

NOTE:
THIS IS A FACTORY INSTALLED OPTION,
WIRE TO THERMOSTAT MS(T)01ES AS SHOWN
IN THIS DIAGRAM.

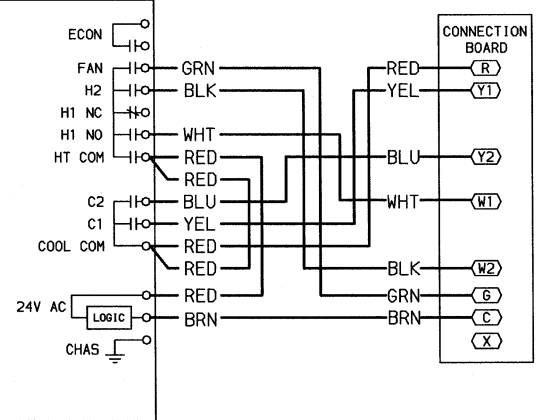

LEGEND

- | | |
|-------------------------------------|--|
| CCS — Carrier Comfort System | OAT — Outdoor Air Thermostat |
| DX — Direct Expansion | SAT — Supply Air Temperature |
| IAQ — Indoor Air Quality | VVT — Variable Volume and Temperature |

NOTE: The relay pack must be wired to a separate transformer. Do not wire to the unit transformer.

Fig. 7 — Relay Pack to HVAC Unit Wiring, 50HJ,TJ016-028 Units

